

GENERAL INSTRUCTION FOR EARTHING:

1. Location of earthing conductors / risers shown in the earthing drawing may change to suit the site condition.
2. Two different risers of one structure/equipment shall be connected to different conductors of main earthmat.
3. Earthing conductor around the building shall be buried at a minimum distance of 1500 mm from the outer boundary of the building.
4. Minimum distance of 6000 mm shall be maintained between two treated (pipe) electrode.
5. For surge arrester, earthing lead from surge counter to main earthmat shall be shortest in length as practically as possible. Earthing lead from surge arrester shall not be passed through any pipe.
6. No welding is allowed in the over ground earthing leads/risers if the length is less than 6m .
7. All ground connections shall be made by electric arc welding. All welded joints shall be allowed to cool down gradually to atmospheric temperature before putting any load on it. Artificial cooling shall not be allowed.
8. All arc welding with MS ROD shall be done with low hydrogen content electrodes. the welds should be treated with red oxide primer and afterwards coated with two layers bitumen compound to prevent corrosion.
9. Wherever earthing conductor crosses cable trenches, underground service ducts, pipes, tunnels, railway tracks etc., it shall be laid minimum 300 mm below them and shall be circumvented in case it fouls with equipment/structure foundations.
10. Earthing conductor around the building shall be buried in earth at a minimum distance of 1500 mm from the outer boundary of the building.
11. Earthing conductors crossing the road shall be laid 300mm below road or at greater depth to suit the site conditions.
12. Earthing conductors embedded in the concrete shall have approximately 50mm concrete cover

RELEASED FOR CONTRUCTION

POWER GRID CORPORATION
OF INDIA LIMITED
(A Government of India Enterprise)



PROJECT :- TECHNICAL SPECIFICATION-
SWITCHYARD ERECTION

TITLE:- STANDARD EARTHING DETAILS

<i>KKPachar</i>	<i>KKPachar</i>	Dec-2013	Drawing No.: C/ENG/STD/EARTHINGS/09 SHEET # 1
CKD BY	PRPD BY	Date	

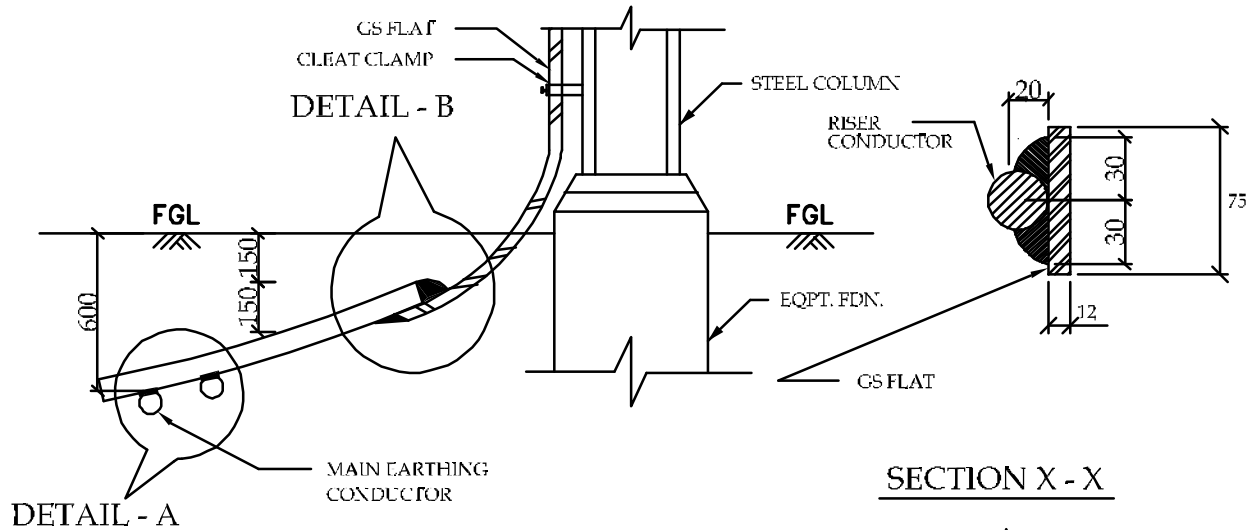

TYPICAL DETAILS OF RISER

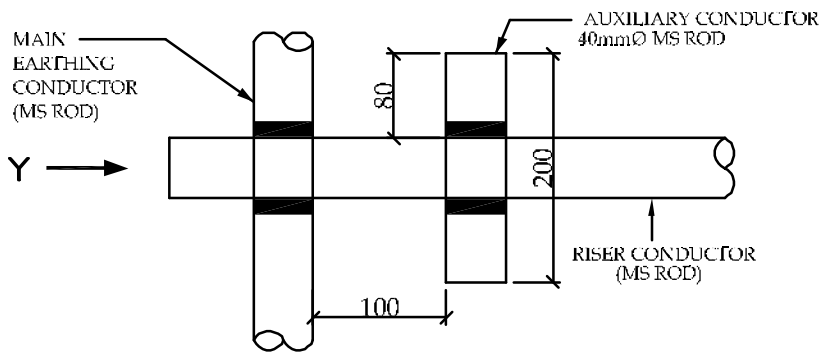

PLAN

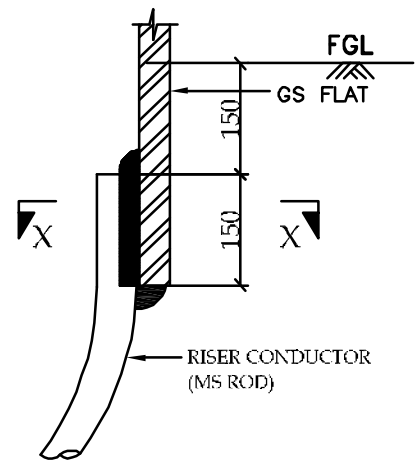

ELEVATION

DETAIL - B

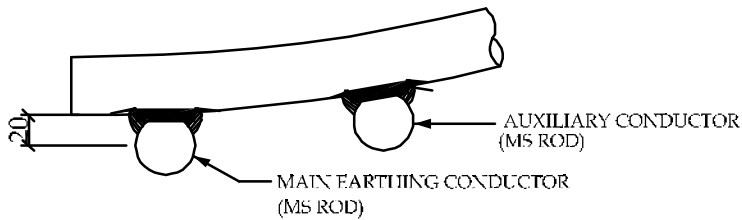

ELEVATION

DETAIL - A

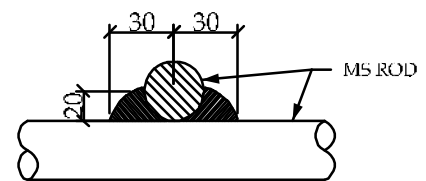

VIEW - Y

RELEASED FOR CONTRUCTION

POWER GRID CORPORATION
OF INDIA LIMITED
(A Government of India Enterprise)



PROJECT :- TECHNICAL SPECIFICATION-
SWITCHYARD ERECTION

TITLE:- STANDARD EARTHING DETAILS

CKD BY	PRPD BY	Dec-2013	Drawing No.: C/ENG/STD/EARTHINGS/09 SHEET # 2
		Date	

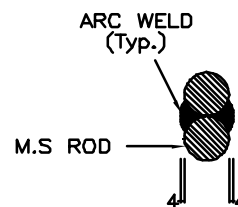
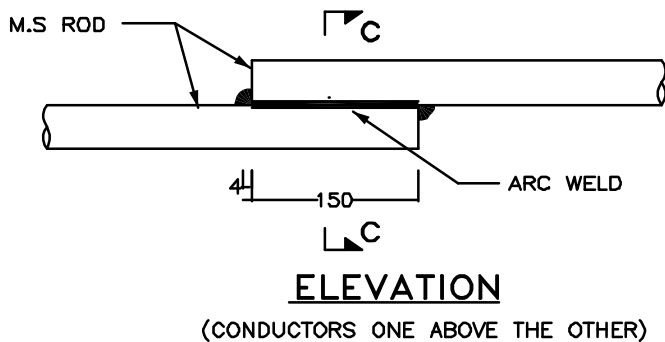
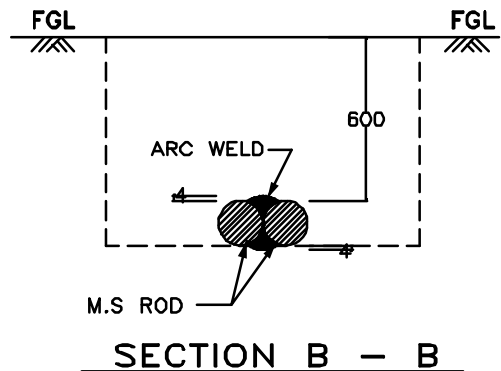
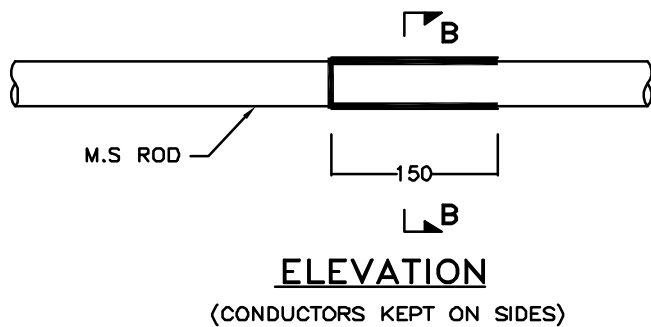
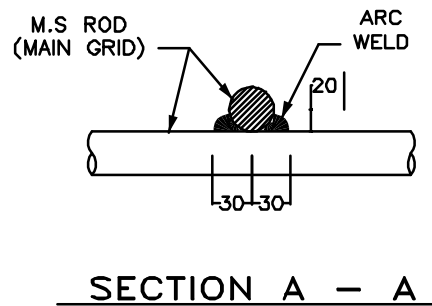
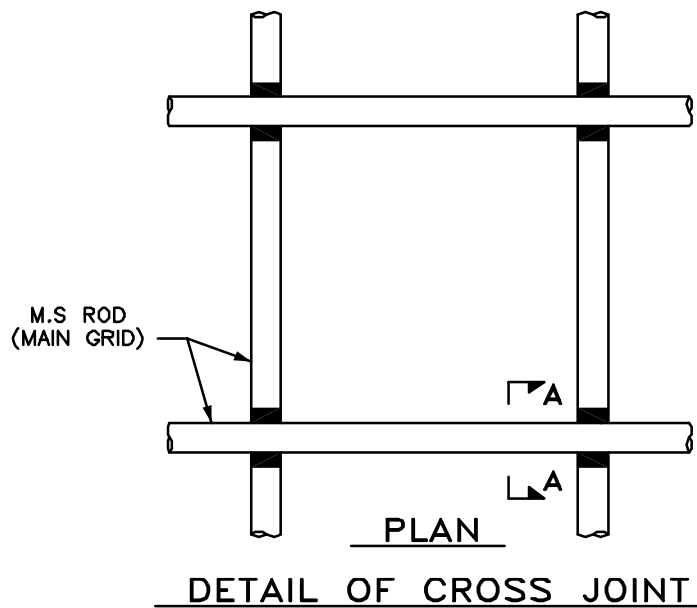

DETAIL OF LAP JOINT

RELEASED FOR CONTRUCTION

POWER GRID CORPORATION
OF INDIA LIMITED
(A Government of India Enterprise)



PROJECT :- TECHNICAL SPECIFICATION-
SWITCHYARD ERECTION

TITLE:- STANDARD EARTHING DETAILS

<i>K.K.Parkar</i>	<i>K.K.Parkar</i>	Dec-2013	Drawing No.: C/ENG/STD/EARTHINGS/09 SHEET # 3
CKD BY	PRPD BY	Date	

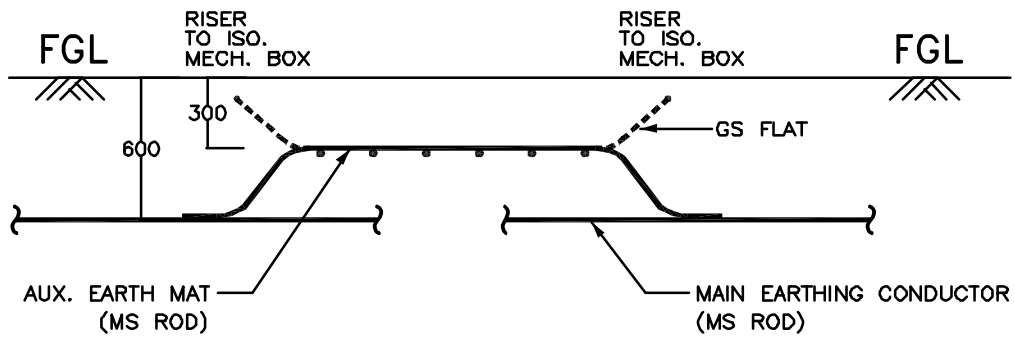

ELEVATION

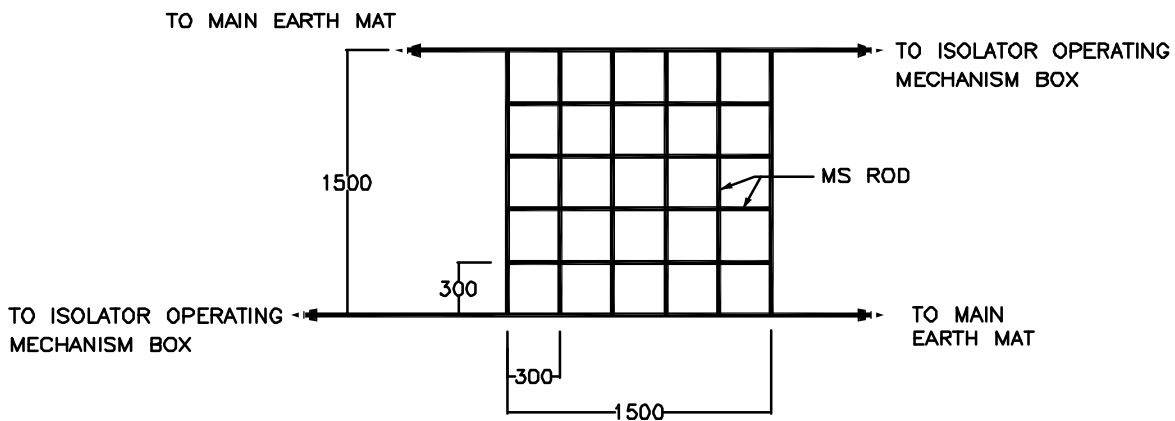

PLAN (For 220kV & above class isolators)

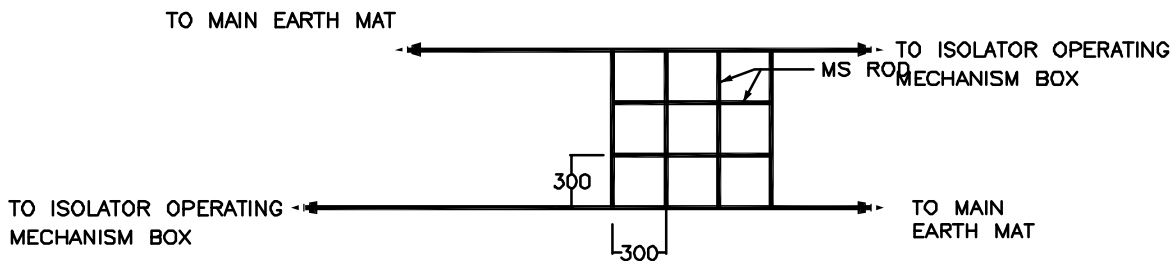

PLAN (For 132kV & below class isolators)

RELEASED FOR CONTRUCTION

POWER GRID CORPORATION
OF INDIA LIMITED
(A Government of India Enterprise)



PROJECT :- TECHNICAL SPECIFICATION-
SWITCHYARD ERECTION

TITLE:- STANDARD EARTHING DETAILS

CKD BY	PRPD BY	Dec-2013	Drawing No.: C/ENG/STD/EARTHINGS/09 SHEET # 4
		Date	

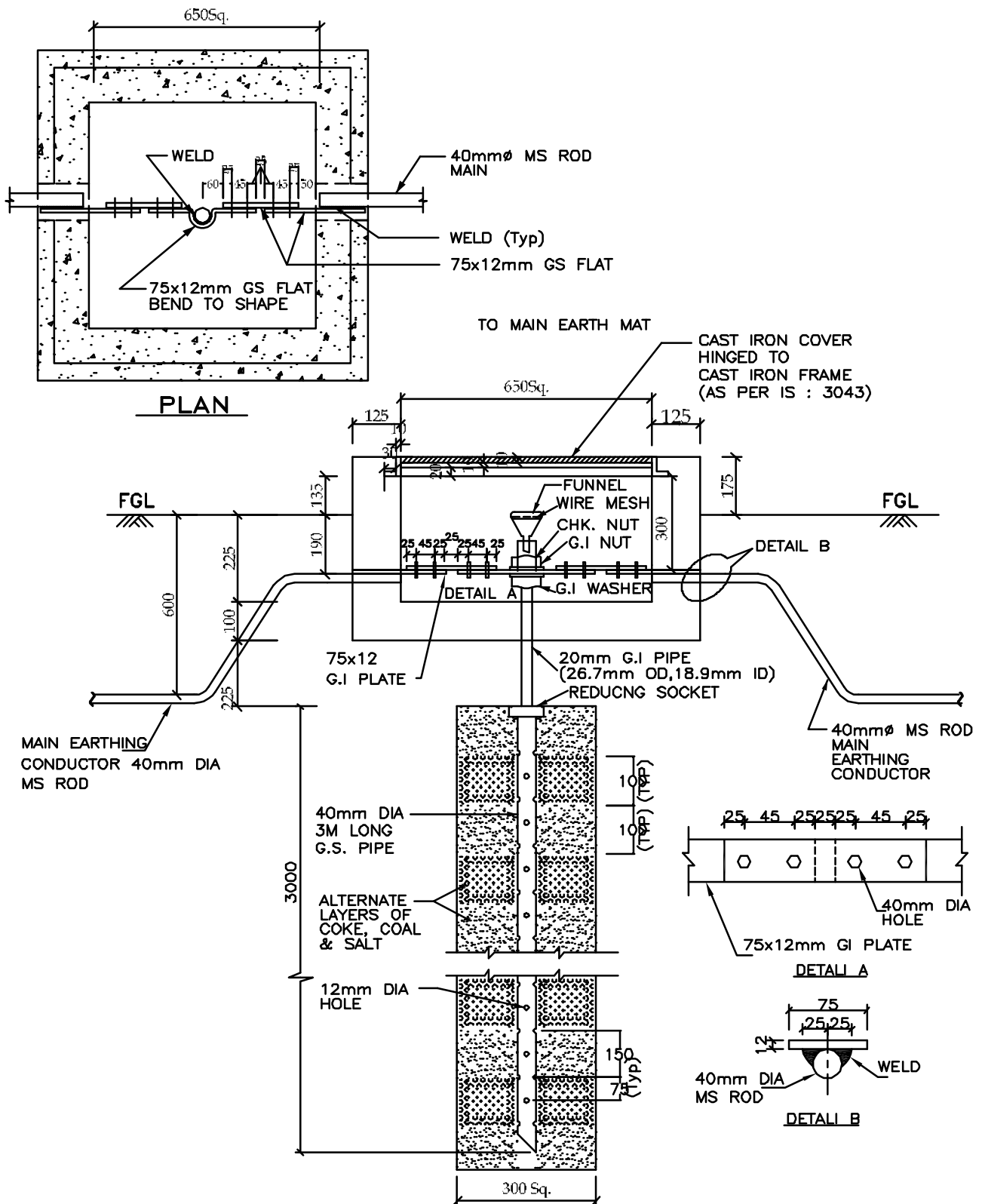

RELEASED FOR CONTRUCTION

POWER GRID CORPORATION OF INDIA LIMITED (A Government of India Enterprise)		 पावरग्रिड
PROJECT :- TECHNICAL SPECIFICATION- SWITCHYARD ERECTION		
TITLE:- STANDARD EARTHING DETAILS		
<i>K.K.Parkar</i> CKD BY	<i>K.K.Parkar</i> PRPD BY	Dec-2013 Date
		Drawing No.: C/ENG/STD/EARTHINGS/09 SHEET # 5

ROD ELECTRODE WITH TEST LINK FOR LM, TOWER WITH PEAK, CVT, LA

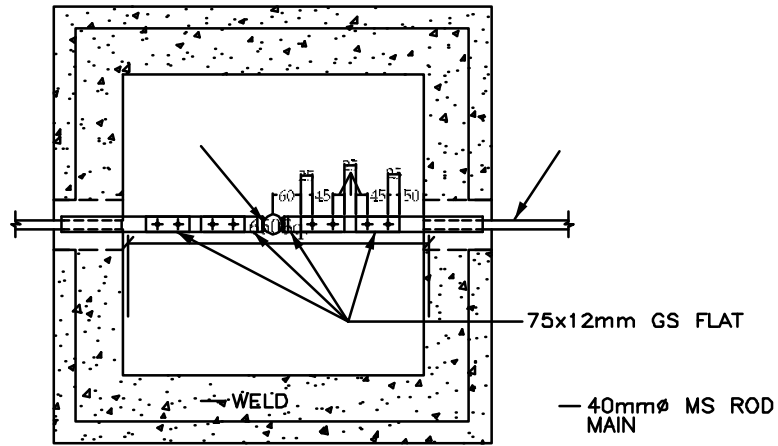

PLAN

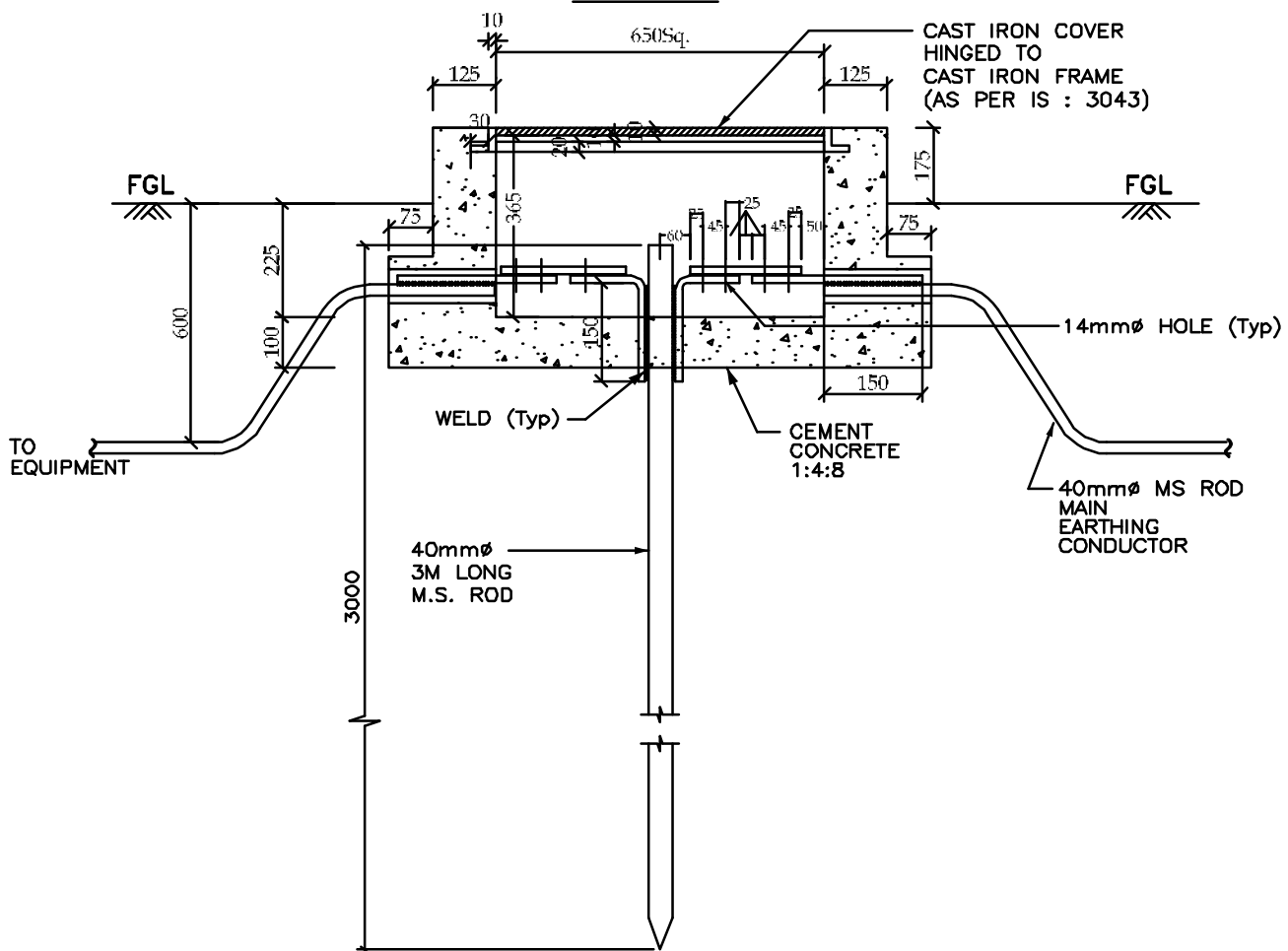

ELEVATION

RELEASED FOR CONTRUCTION

POWER GRID CORPORATION
OF INDIA LIMITED
(A Government of India Enterprise)



PROJECT :- TECHNICAL SPECIFICATION-
SWITCHYARD ERECTION

TITLE:- STANDARD EARTHING DETAILS

CKD BY	PRPD BY	Dec-2013	Drawing No.: C/ENG/STD/EARTHINGS/09 SHEET # 6
		Date	